



MAGAZINE LOADER CE TYPE

Automatically loads PCB's of magazine and tranfers to next process

FEATURES

- SMEMA interface
- Dual clamping system for magazine warp prevention
- Easy operation with "Easy S/W"
- Compact design
- LED tower light
- Alarm code display
- PCB pushing guide

OPTIONS

- 2 Kinds selectable magazine size
- Touch screen
- High speed magazine exchange (19 sec.)
- Aux. Buffer conveyor
- 5 Rack magazine capacity (Up:2, Down:3)
- PCB damage prevention (Jam detection)

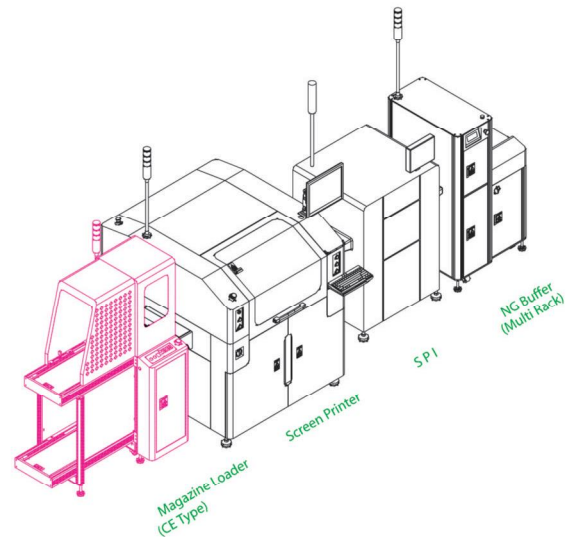
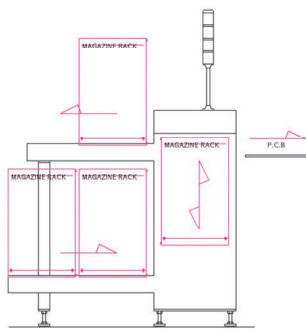

MODEL	TYPE	RACK	Max.PCB(L×W)	Min.PCB(L×W)	DIMENSION(L×W×H)	POWER	AIR	WEIGHT(Kg)
ALD-12CE	S	3	330×250	50×50	1170×810×1670	0.3kVA	0.5±0.1	180
	Y		440×330	50×65	1480×922×1670			200
	L		530×375	50×60	1750×992×1670			220
	XL		530×460	50×100	1750×1002×1670	0.4kVA		240
	2XL		610×460	50×100	2020×1062×1670			250

Customized Manufacturing Available.